

Red, White and Blue Star 25" Mini Quilt • for Painter's Palette Solids
 Designed by Elizabeth Eastmond of OccasionalPiece-Quilt (*OPQuilt.com*)

Collect yourself some fat quarters in reds, blues and brilliant white to make a quick and easy patriotic table topper, perfect for your 4th of July celebrations.

Cutting Chart

Fat quarters are needed in three different reds, three different blues and white.

Color	Piece (Template and piece)	Cutting Directions
White	Triangles (B)	Cut TWO: 5-3/4" squares, cut in half diagonally to yield four pieces. The grain is on outside right-angle edges.
	Outer Border	Cut FOUR: 21-1/2" by 2-1/2" long, thin rectangles. ***NOTE: Cut this FIRST! see below for details***
Light Blue	Star Point Triangles (B)	Cut FOUR: 5-3/4" squares, cut in half diagonally to yield eight pieces. The grain is on outside right-angle edges.
Medium Blue	Center Square (E)	Cut ONE: 5-3/8" square
	Triangles (A), outer corners	Cut TWO: 7-7/8" squares (A), cut in half diagonally to yield 4 pieces
Dark Blue	Triangles, outer side (C)	Cut ONE: 8-1/4" then cut diagonally into fourths, yielding 4 pieces, with grain of fabric on longest edge.
	Triangles (F)	Cut FOUR: 4-3/8" squares, cut in half diagonally to yield 8 pieces
Red	Triangles (D)	Cut TWO: 4-3/8" squares, cut in half diagonally to yield 4 pieces
Medium Dark Red	Small Triangles (G)	Cut TWO: 4-3/8" squares, cut in half diagonally to yield 4 pieces
Dark Red	Small Triangles (G)	Cut TWO: 4-3/8" squares, cut in half diagonally to yield 4 pieces
	Cornerstones	Cut FOUR: 2-1/2" squares (Can also use Red)

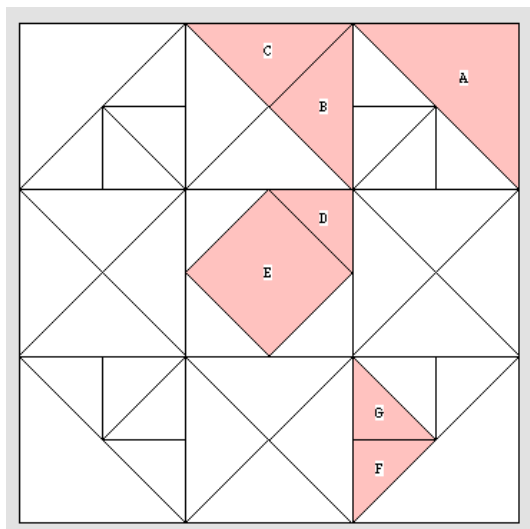
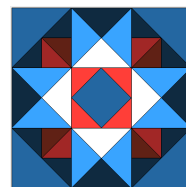

The version without the border strips finishes at 21" square.

***Be sure to cut your white strips FIRST, perpendicular to the selvage, so you'll have enough length for your border. I trimmed one end but left the other un-cut, in case the quilt is slightly larger than the sought-after 21-1/2" (I like flexibility in my creating.)

Here's another view of this same block, done in a different set of solids:

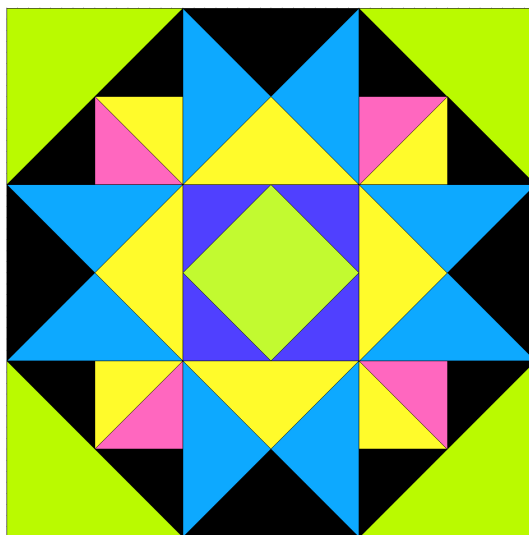

The basic construction is a nine-patch, meaning, construct the nine different sections of the block, then sew them together as you would for a nine-patch.

I put some tips up on the blogpost on OPQuilt.com associated with this project: do a search in the search bar for "Red, White, and Blue Star" and you should find it.

You can also find it under "200 Quilts" as it will be listed as number 183.

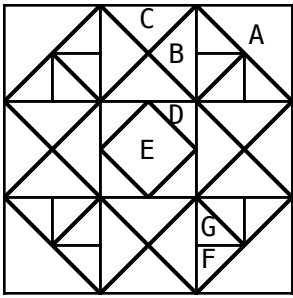

Templates

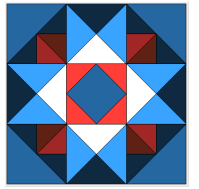
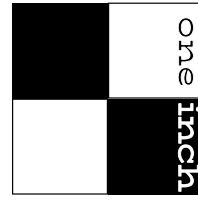

Tip sheet by Elizabeth Eastmond | OPQuilt.com

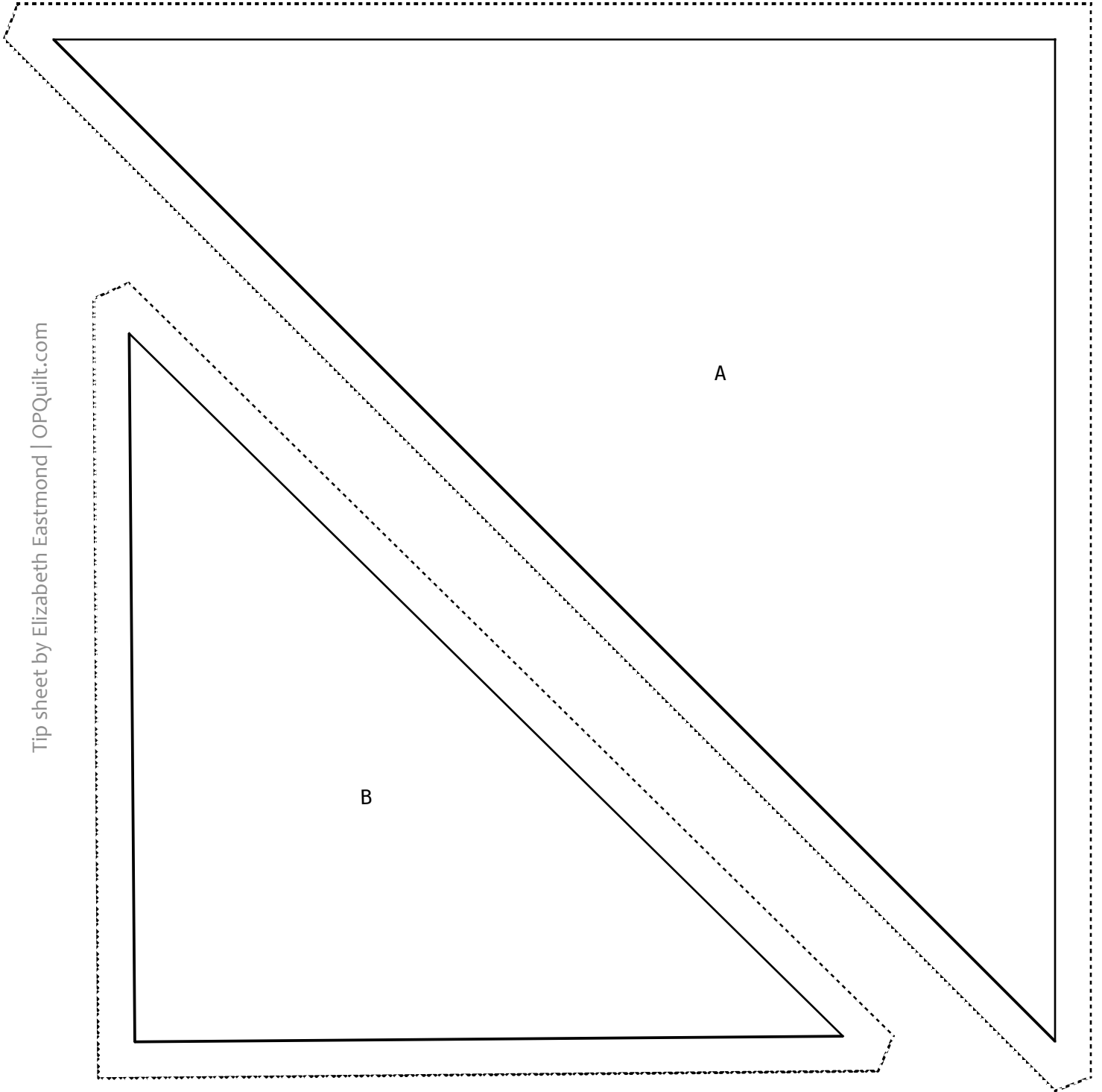

Red, White & Blue Star

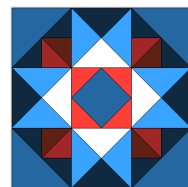

Tip sheet by Elizabeth Eastmond | OPQuilt.com

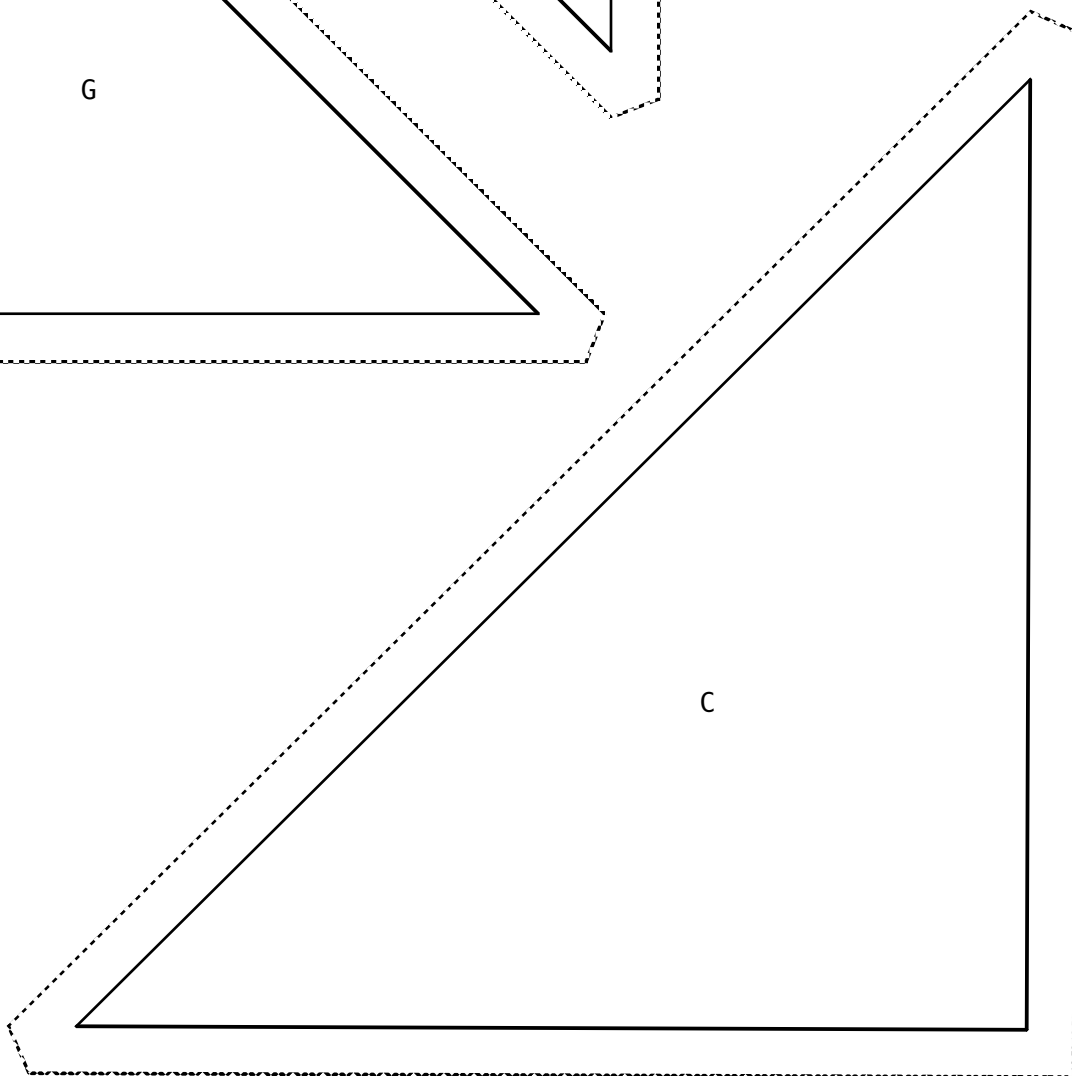
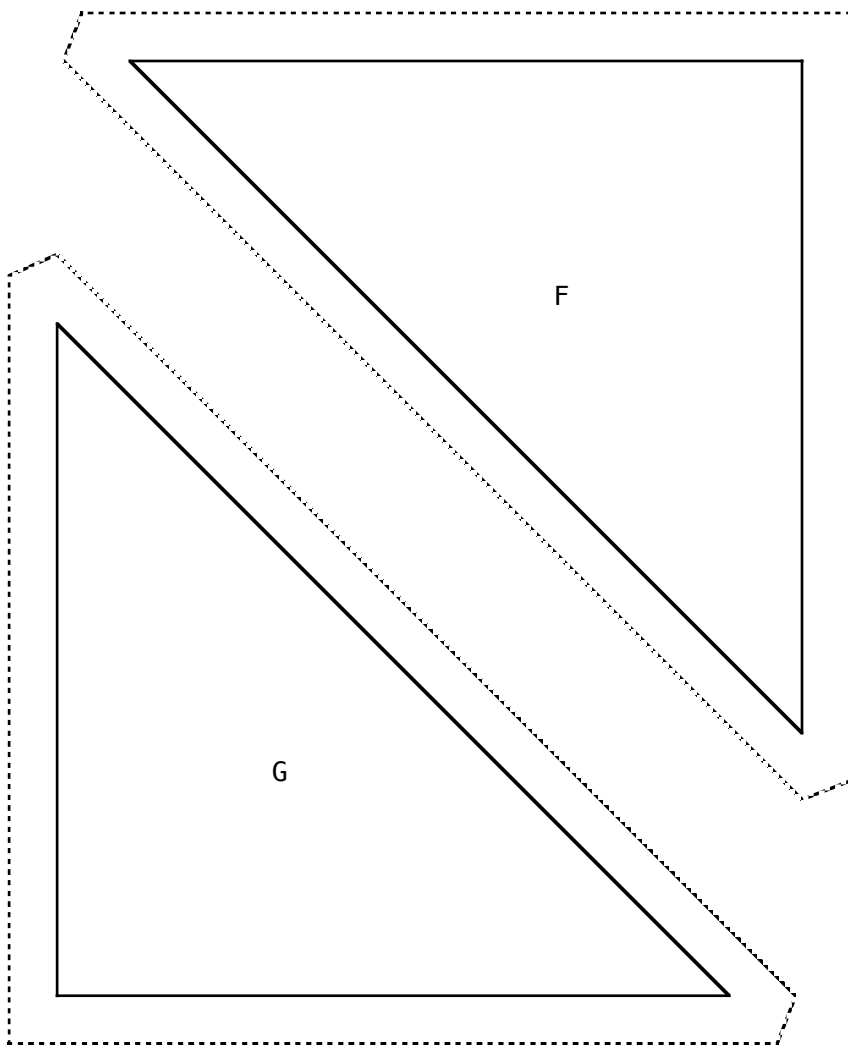
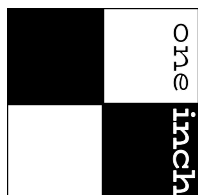

Red, White & Blue Star

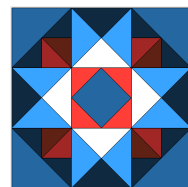

Tip sheet by Elizabeth Eastmond | OPQuilt.com

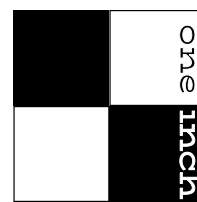
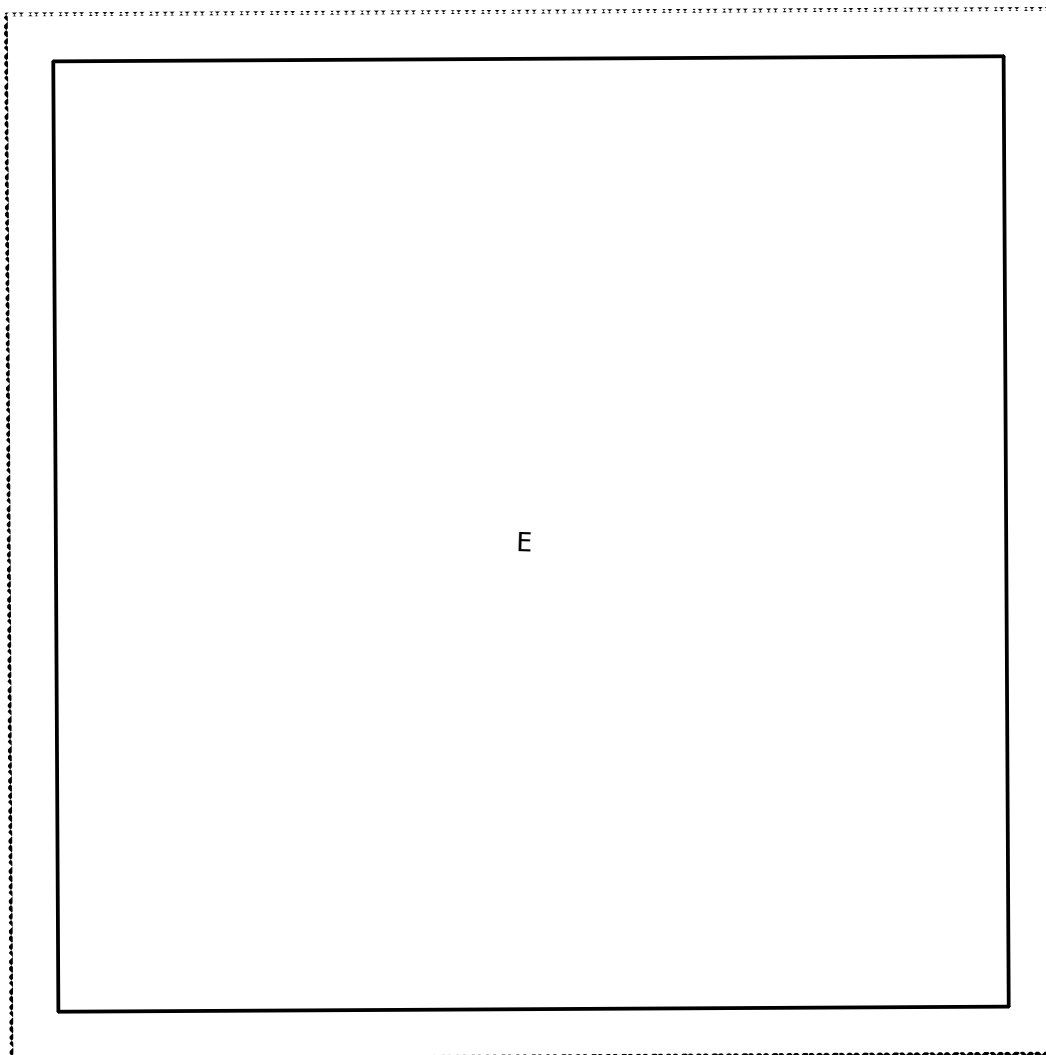

Write if you have any questions.
Hope your mini-quilt is festive!

Elizabeth
OPQuilt.com 1 2 3 4 5 6 7 8

Elizabeth Eastmond
Email: opquilt@gmail.com
Web: www.opquilt.com
Instagram: [occasionalpiecequilt](https://www.instagram.com/occasionalpiecequilt)

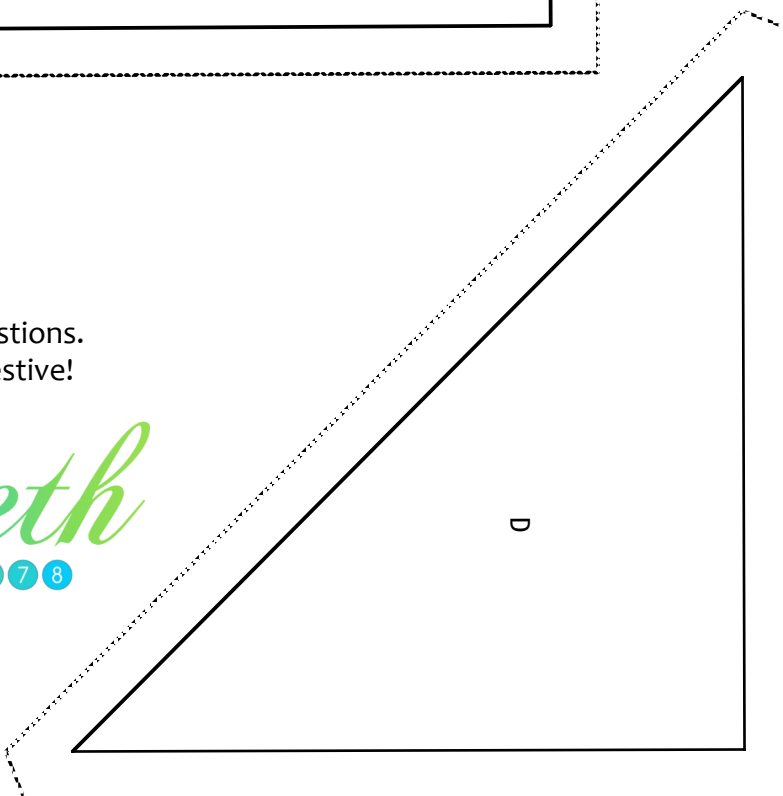

Red, White & Blue Star